

# KOMPAKT



mały,  
lekki,  
łatwy w obsłudze

ograniczone możliwości,  
ustawienia

# LUSTRZANKA



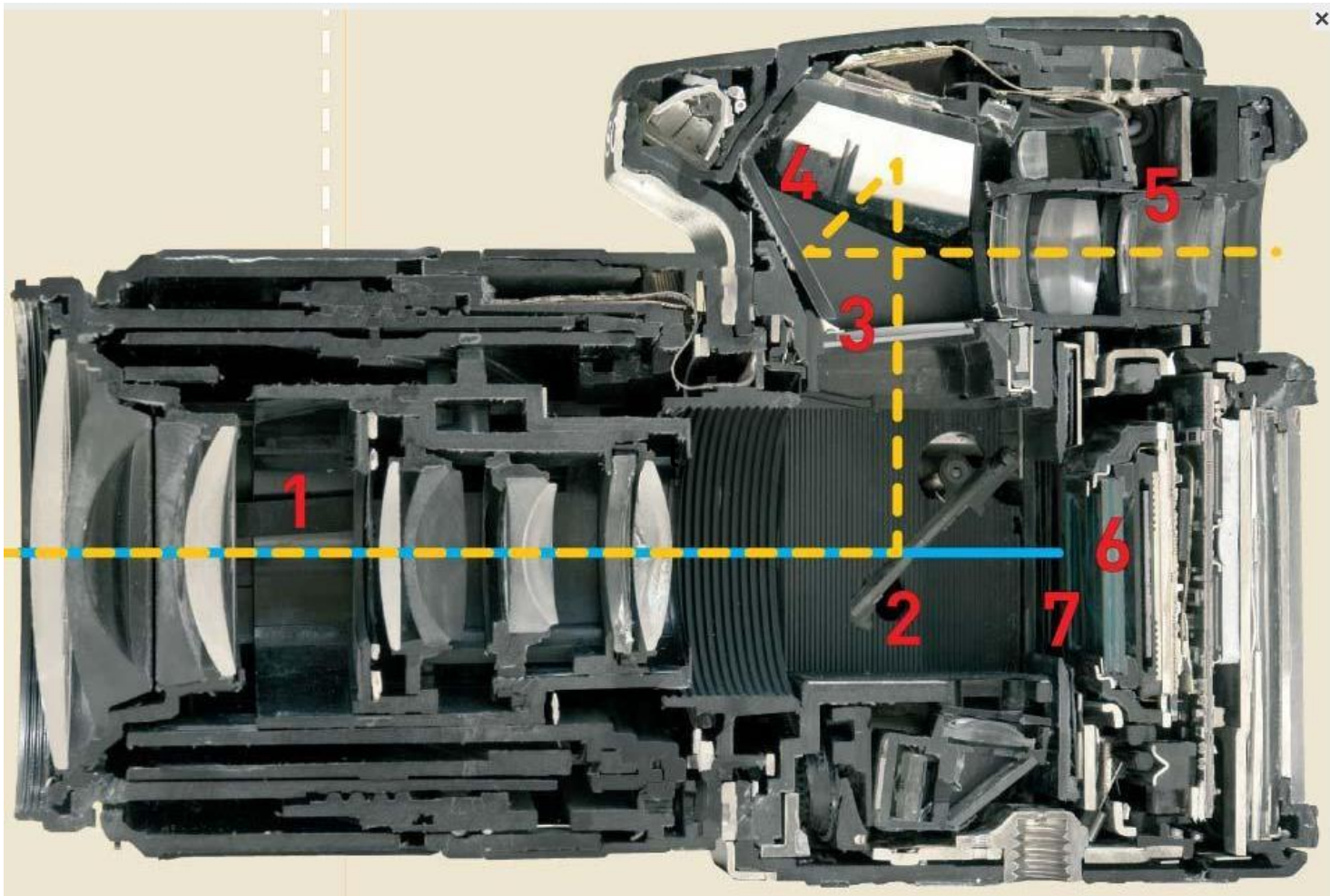

1. Wymienny obiektyw
2. Ruchome lustro
3. Matówka
4. Pryzmat
5. Wizjer
6. Matryca/klisza
7. Migawka

# CAMERA OBSCURA

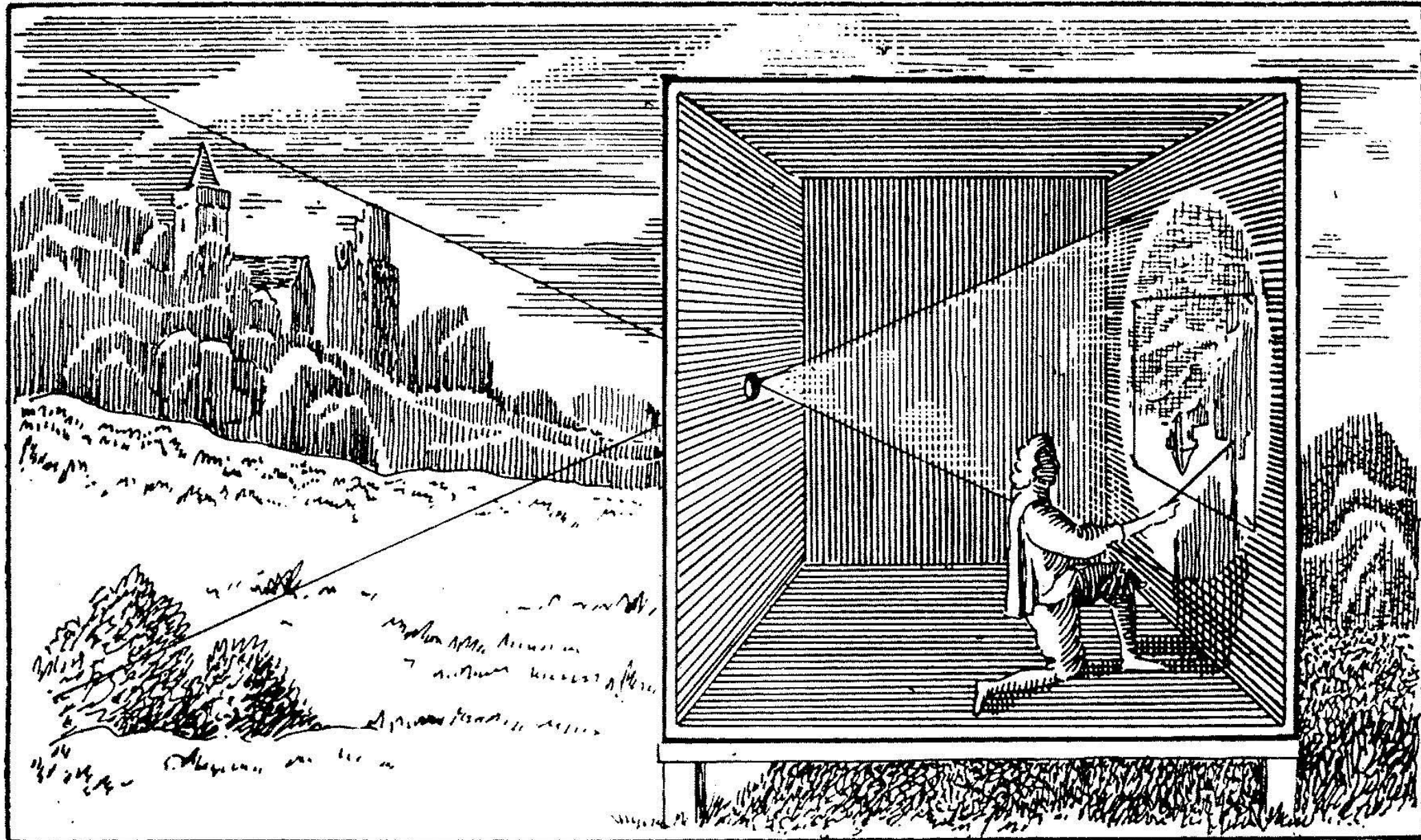





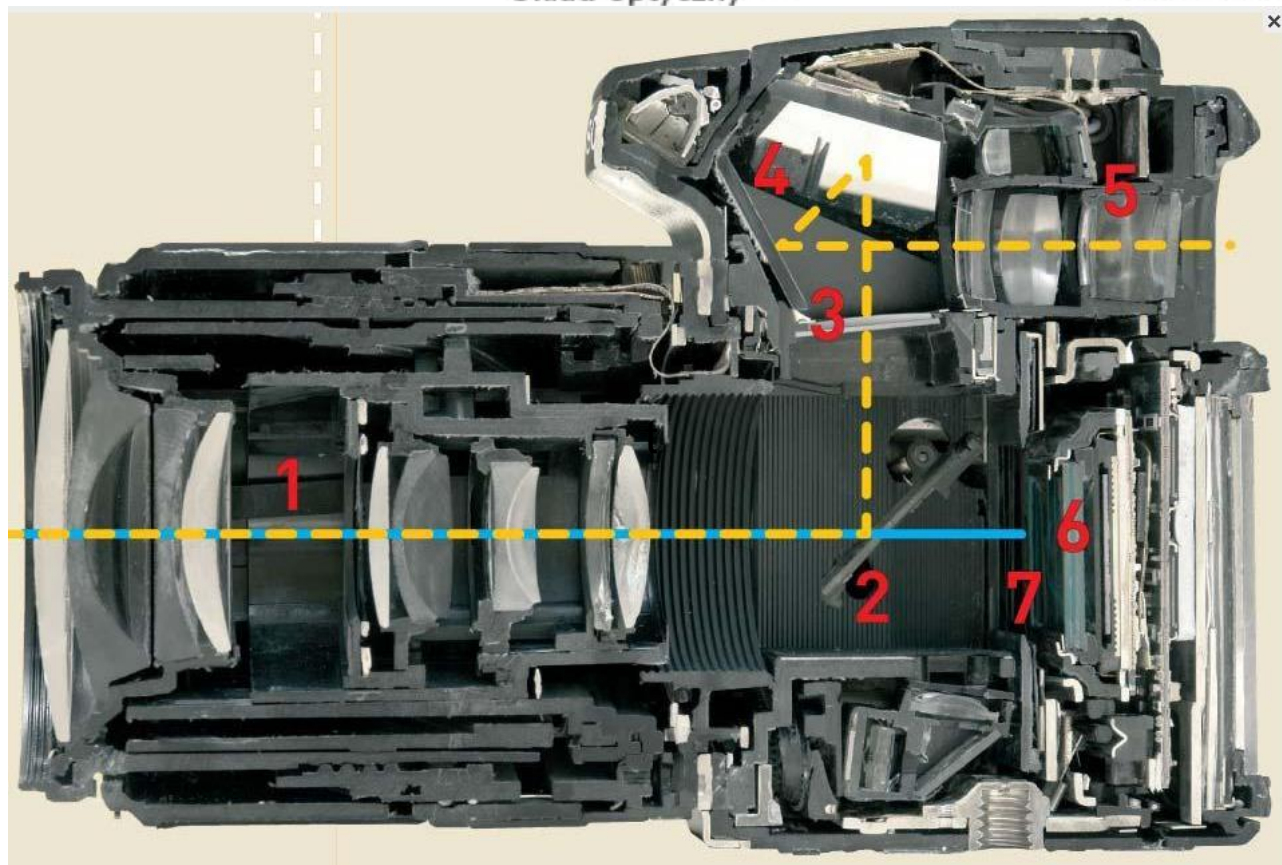
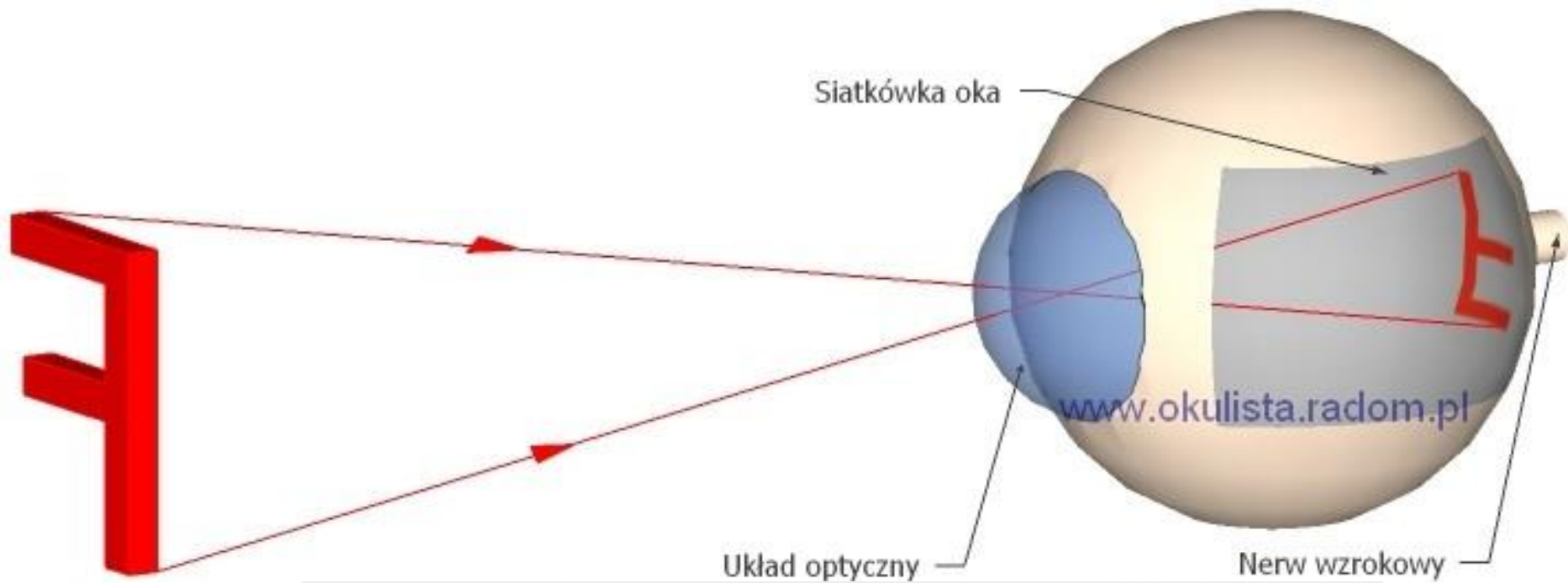



Exposure time

F-number

ISO speed

1/15

F4.5

ISO 100

P

-2..1..0..1..+2

S

AWB

Camera icon

RAW + L

ONE SHOT

Frame icon

SET Q

Battery icon

( 71 )

# CZAS (otwarcia migawki)

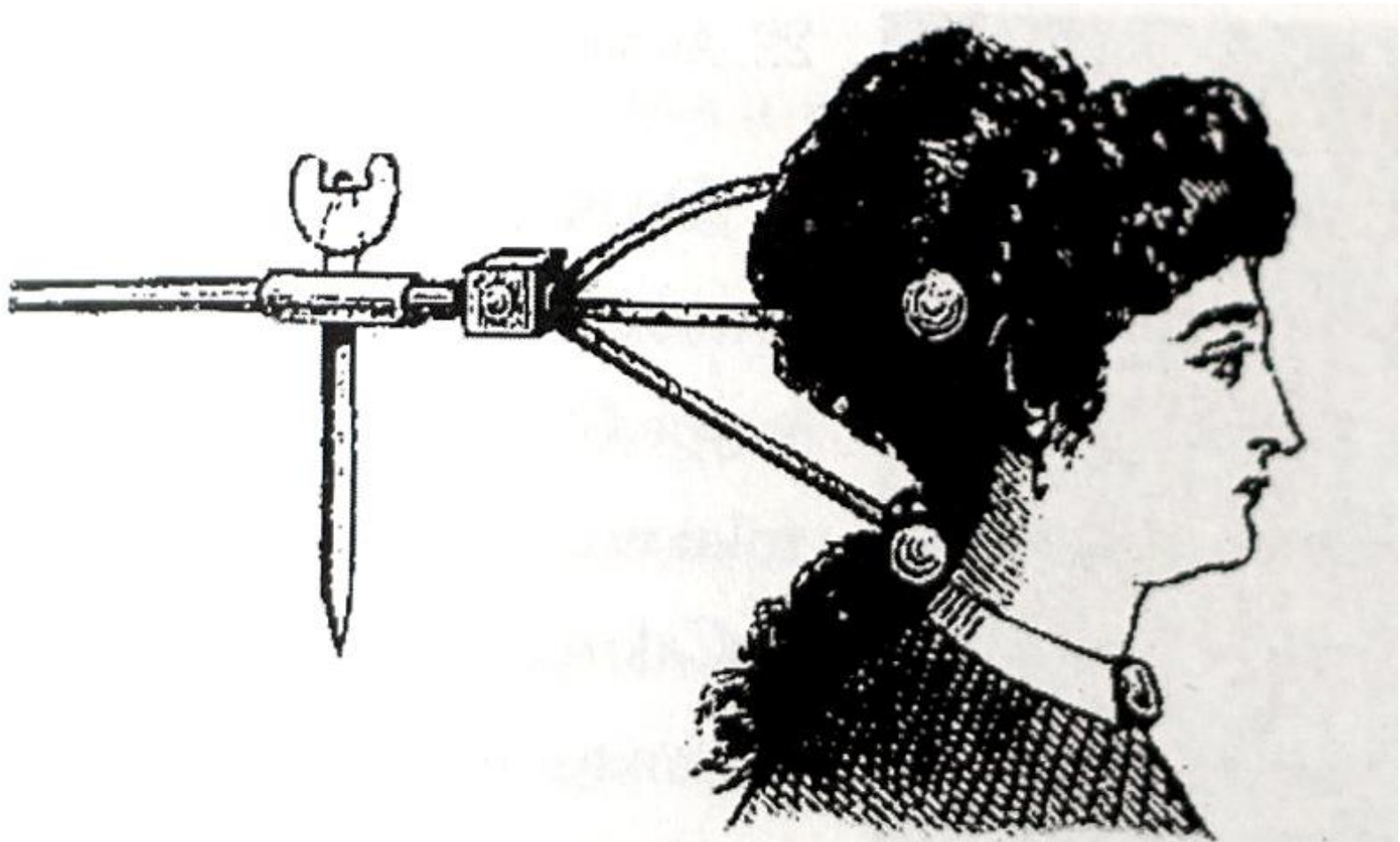

19. Podpórka do podtrzymywania głowy podczas pozowania.



1/2	1"
1/4	2"
1/8	3"
1/15	4"
1/30	...
1/60	30"
1/90	B
1/125	
1/250	
1/500	
...	
1/8000	

# Krótki czas

Zamrożenie ruchu

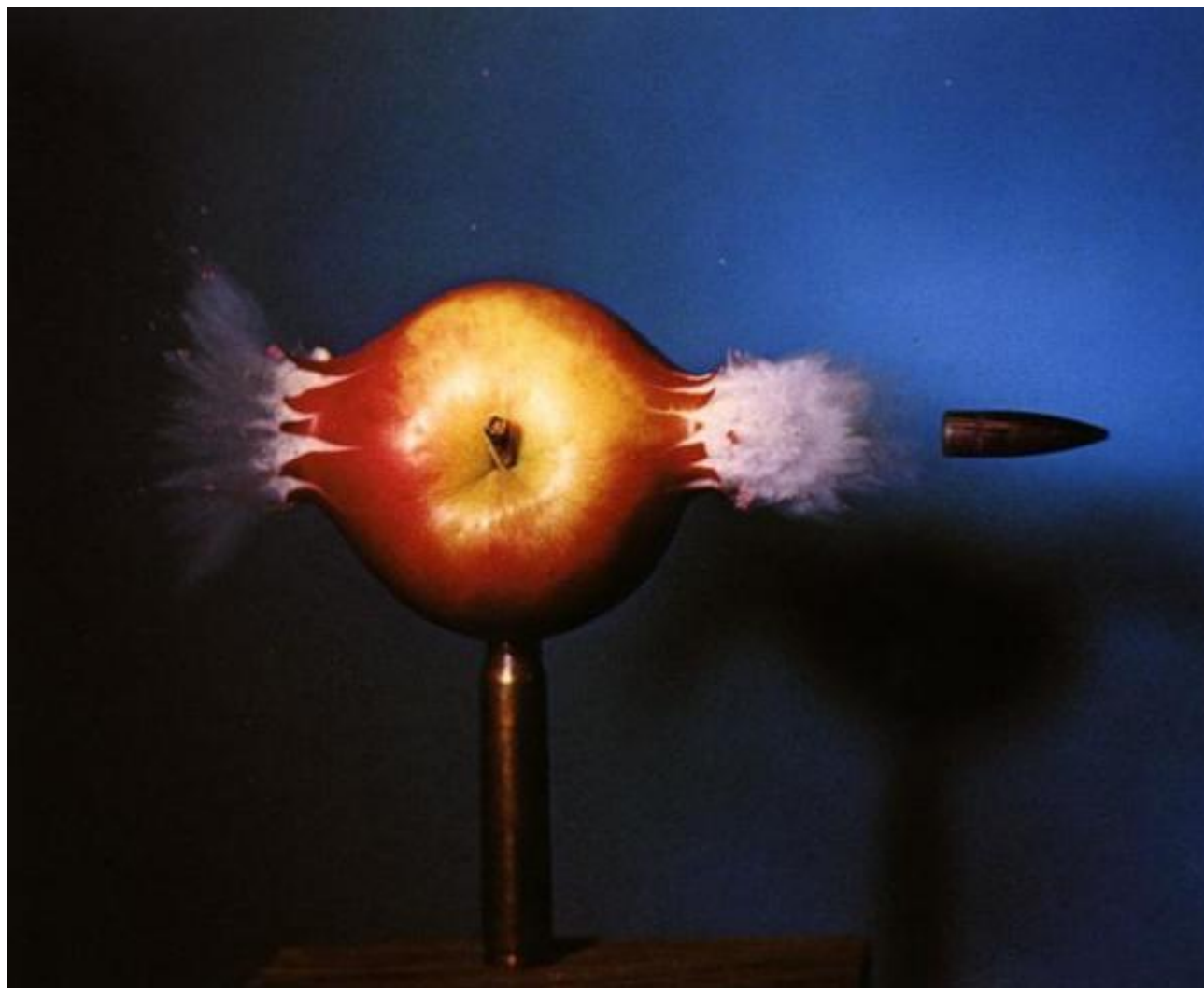











# Długi czas

Rozmycie





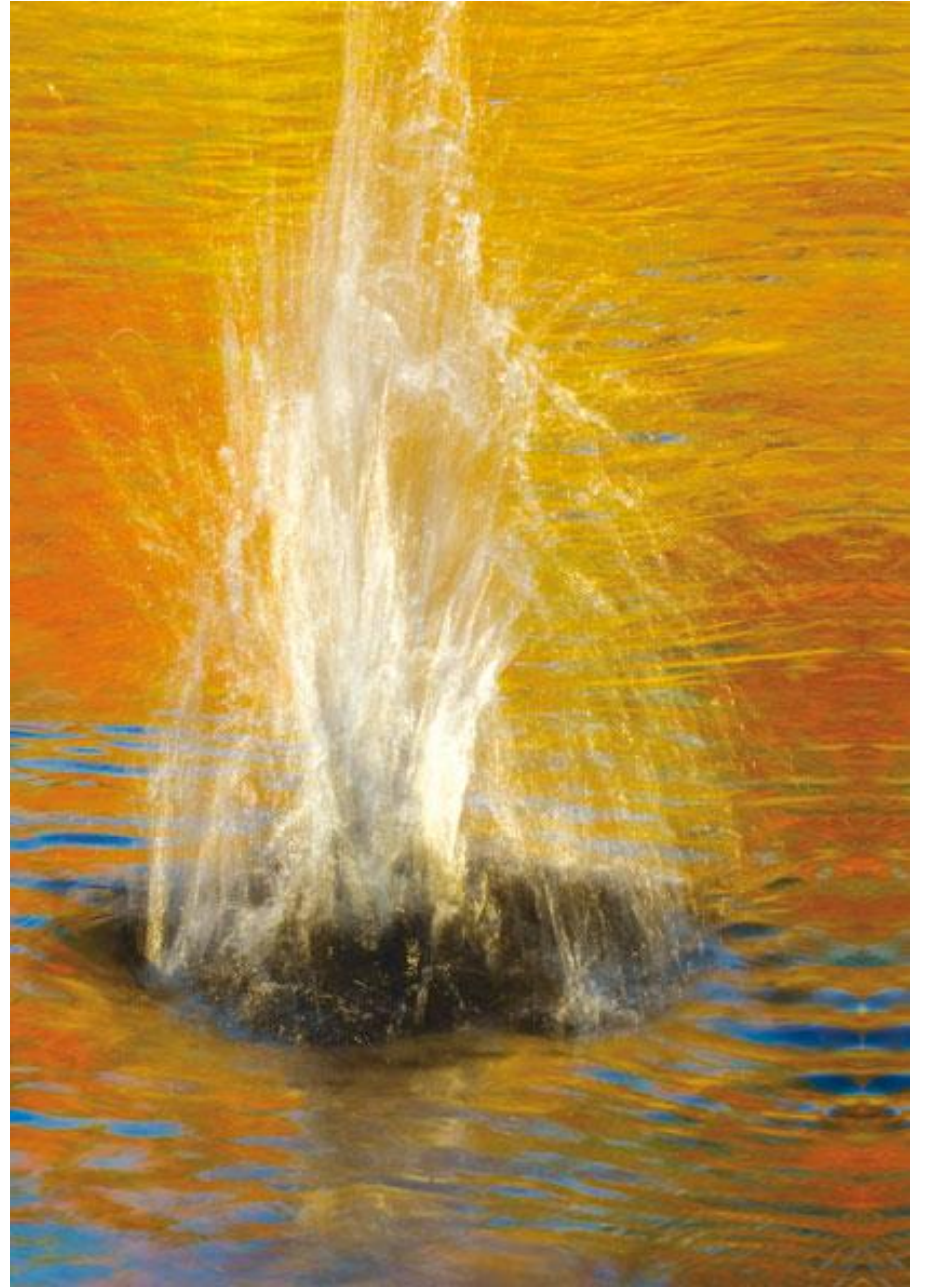







Alexy Titarenko – City of shadows







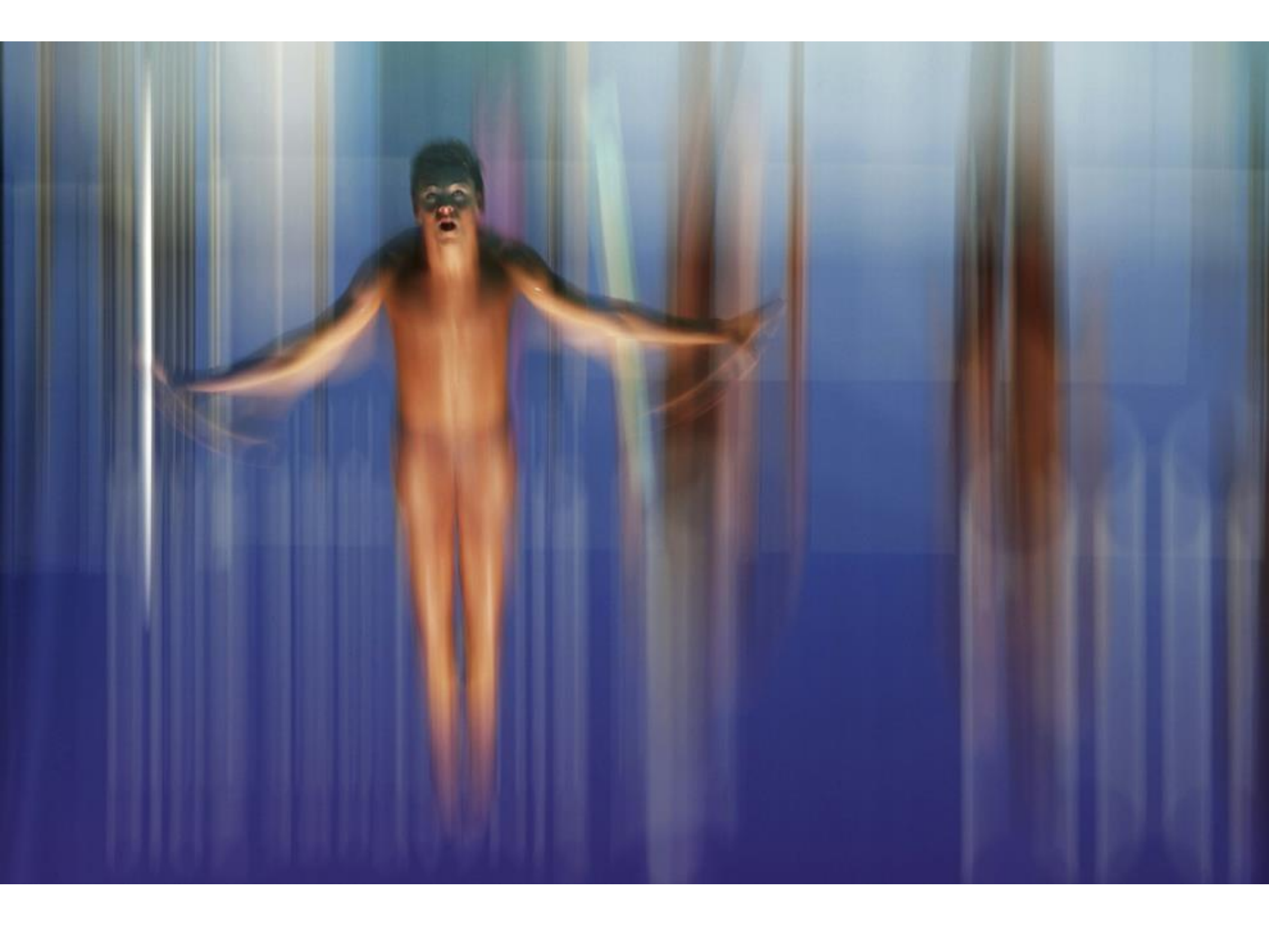



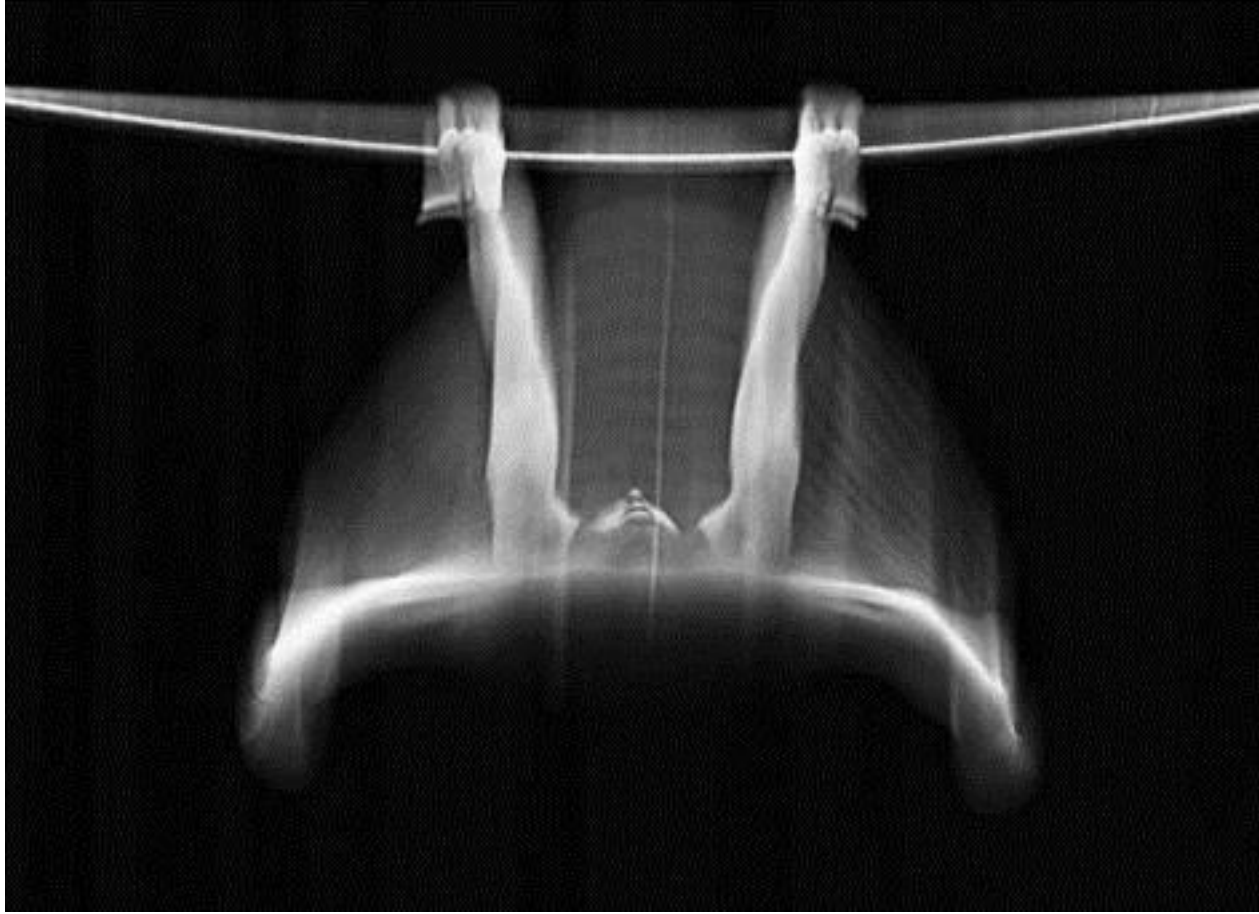

# PRZYSŁONA (f)

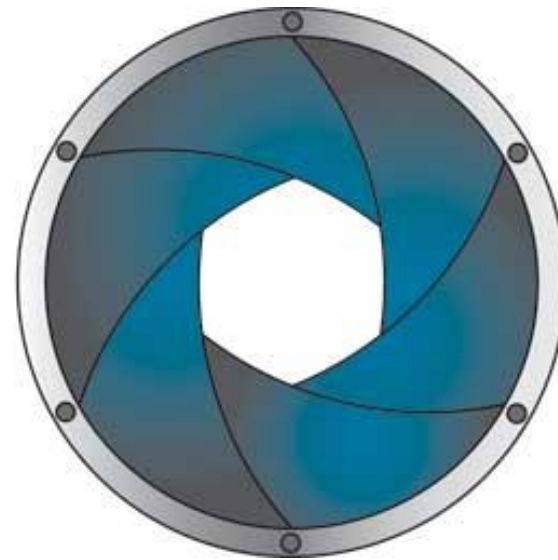
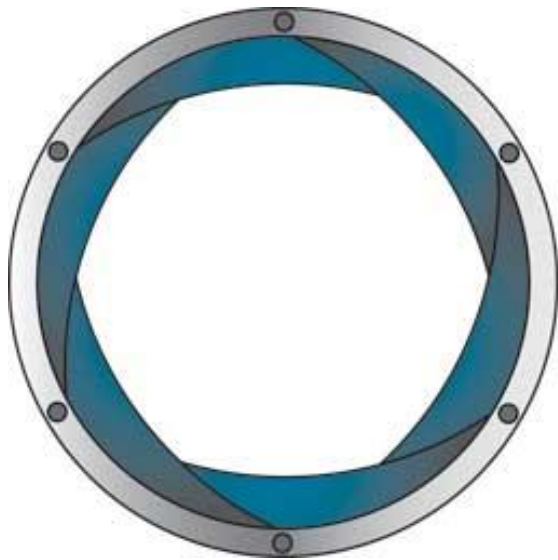

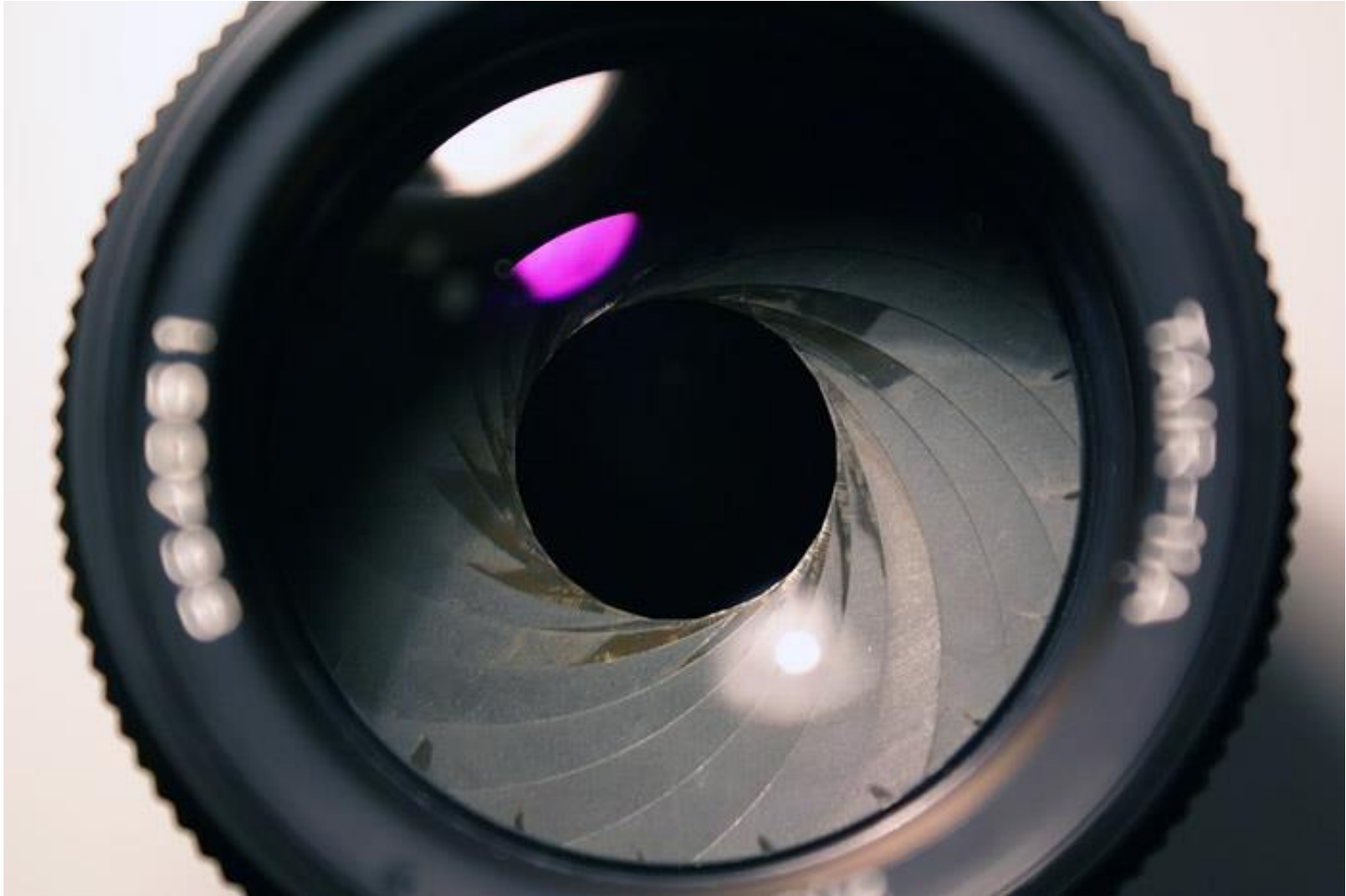





F/1,4

F/1,8

F/2

F/2,8

F/3,5

F/4

F/4,5

F/5,6

F/8

F/11

F/16

F/22

F/32

...

Mała przysłona

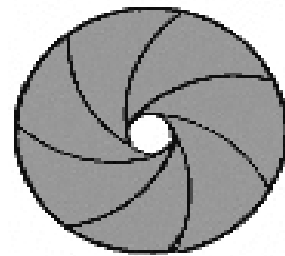
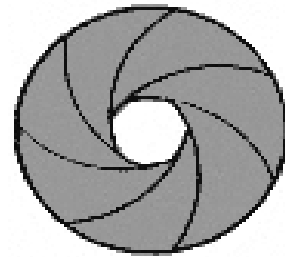
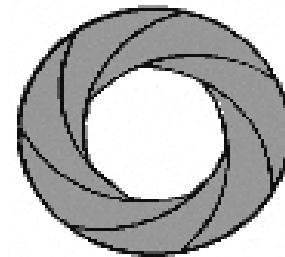
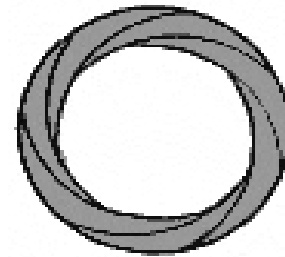

Duża przysłona

# Głębina ostrości

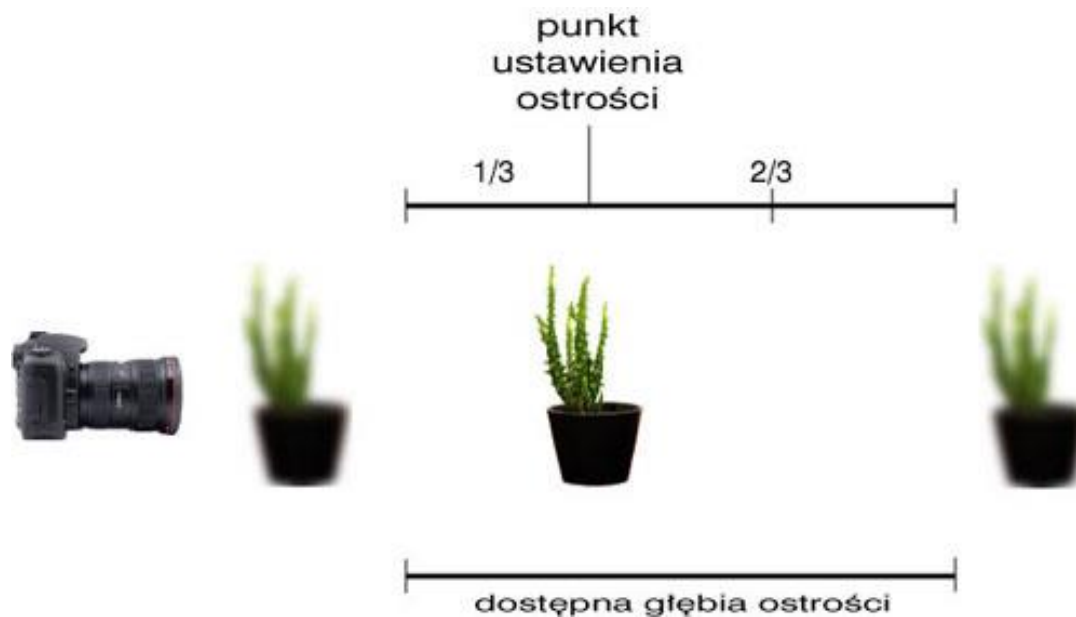
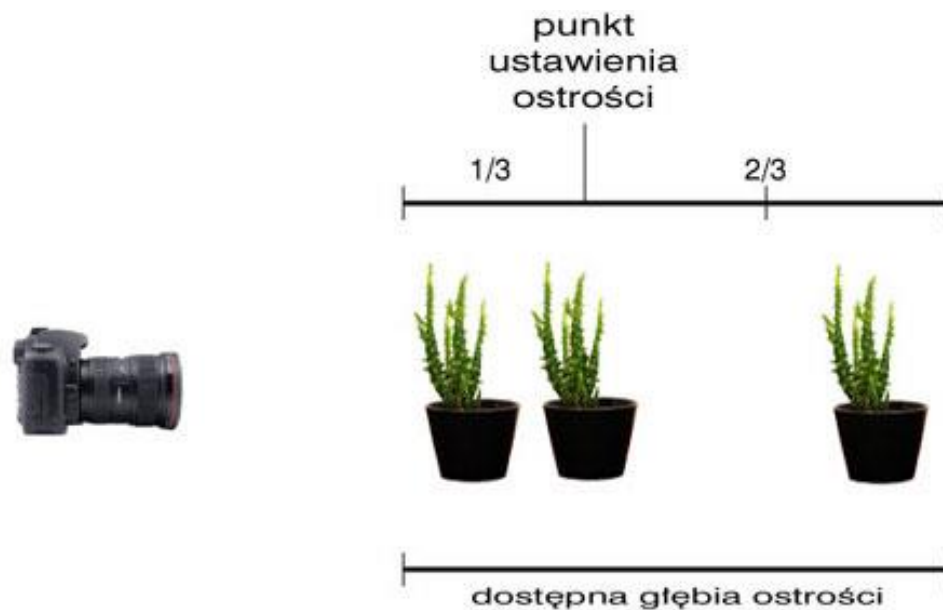













# CZUŁOŚĆ (ISO)

50

100

200

400

800

1600

2000

3200

6400

...

Im większa czułość...

...tym krótsze czasy naświetlania

ale...

gorsza jakość zdjęcia





# Szumy





AUTOMAT  
P

Preselekcja Przystony  
AV / A

Preselekcja Czasu  
TV / S

MANUAL  
M

